



Received for publication, October, 30, 2017

Accepted, January, 9, 2018

*Original paper*

## ***Effects of disinfectant solutions incorporated in dental stone on setting expansion, compression and flexural strength of dental models***

LUMINIȚA OANCEA<sup>1</sup>, LORELAI GEORGETA BILINSCHI<sup>2</sup>, MIHAI BURLIBAȘA<sup>1\*</sup>, ALEXANDRU PETRE<sup>1</sup>, MARIN SANDU<sup>3</sup>, ȘERBAN COSTELA<sup>4</sup>, BIANCA DELIU<sup>1</sup>, GABRIELA TĂNASE<sup>1</sup>, VIOREL ȘTEFAN PERIEANU<sup>1</sup>, RADU COSTEA<sup>1</sup>, MĂDĂLINA VIOLETA PERIEANU<sup>1</sup>, MIHAI DAVID<sup>1</sup>, OANA CELLA ANDREI<sup>1</sup>, MĂDĂLINA ADRIANA MALIȚA<sup>1</sup>, NARCIS MARCOV<sup>1</sup>, MIHAELA ROMANIȚA GLIGOR<sup>5</sup>, CAMELIA IONESCU<sup>1</sup>, BOGDAN PAVĂL<sup>5</sup>, CORINA MARILENA CRISTACHE<sup>1</sup>, ILEANA IONESCU<sup>1</sup>

<sup>1</sup>“Carol Davila” University of Medicine and Pharmacy Bucharest, Romania

<sup>2</sup>University of Medicine and Pharmacy Targu Mures, Romania

<sup>3</sup>University Politehnica of Bucharest, Romania

<sup>4</sup>“Victor Babes” University of Medicine and Pharmacy Timisoara, Romania

<sup>5</sup>“Lucian Blaga” University of Sibiu, Romania

<sup>6</sup>Private Dental Office, Romania

### **Abstract**

**Purpose of the study:** The aim of the study is to analyze the way the disinfectants embedded in the plaster affect the setting linear dimensional stability, flexural and compressive strength of dental stone models.

**Material and Methods:** Samples were made of type IV dental stone in which different disinfectants had been incorporated (sodium hypochlorite 1%, chlorhexidine 2%) in two concentrations (50%, 100%), thus obtaining four test groups. Mentioned parameters are measured using a micro comparison device and an universal testing machine, analyzing statistically the results in comparison with the control group, prepared by standard indications.

**Results:** Disinfectants cause a decrease of the setting expansion value ( $\Delta L$ ) compared to the standard group in all type of mixing percentage. Variations of compressive and flexural strength are statistically significant, particularly when adding 100% of hypochlorite 1%.

**Conclusions:** Within the limits of this study, replacing the distilled water with disinfectants, alter the value of setting expansion and cause the model dental stone to be brittle in compression and bending.

**Keywords** Dental stone models, disinfection.

**To cite this article:** OANCEA L, BILINSCHI LG, BURLIBAȘA M, PETRE A, SANDU M, COSTELA Ș, DELIU B, TĂNASE G, PERIEANU VȘ, COSTEA R, PERIEANU MV, DAVID M, ANDREI OC, MALIȚA MA, NARCIS MARCOV, GLIGOR MR, IONESCU C, PAVĂL B, CRISTACHE CM, IONESCU I. Effects of disinfectant solutions incorporated in dental stone on setting expansion, compression and flexural strength of dental models. *Rom Biotechnol Lett.* 2020; 25(6): 2095-2102. DOI: 10.25083/rbl/25.6/2095.2102

## Introduction

In dentistry, dental impressions and models are considered potentially contaminated sources with various pathogens from patients' blood and saliva. The most commonly disinfection methods used in the dental office and dental laboratory are immersion (ABDULLAH, KUMAR & al, PAL & al [1-3]) or spraying with disinfectants (MANSFIELD & al, STERN & al [4-5]) of the models, but each method has its advantages and disadvantages.

In the attempt to find an optimum method to reduce, the risk of cross-contamination, Donovan Chee [6] tested a new dental stone for models (Steride) in 1989, which contained Chloramine-T. After conducting tests, the authors reported physical properties comparable with those of classic dental stone in almost all aspects.

Schutt [7] also reported that by using Steride product the same disinfection had been obtained for the dental impression of an irreversible hydrocolloid as for the die cast, after 60 minutes from the setting of the dental stone.

Tebrock et al. [8] concluded in their study that the die cast without microbial contamination could be obtained by replacing the distilled water necessary for preparing of the dental stone in a ratio of 25%, with 5.25% sodium hypochlorite.

Other studies (ZARAKANI & al, SWATANTRA & al [9, 10]) which tests the same hypothesis, conclude that replacing the distilled water with sodium hypochlorite has no effect on the setting time, the setting expansion or compressive strength of the model obtained, recommending this method of disinfection in dental labs.

However, contradicting earlier studies, Breault L.G. [11] has examined the quality of the die dental stone, replacing 10% of the water with 5.25% sodium hypochlorite solution, and concluded that this modification increases the compressive strength and the rigidity of the dental stone, without changes in terms of tensile strength or setting expansion.

K.M. Abdelaziz [12] tested the resistance on compression and tensile forces of modified dental stone and showed that disinfectants reduced the hardness of both types of die stone, contradicting the findings of Breault.

However, studying the influence of incorporation of disinfectants in dental stone, Lucas M.G. [13] pointed out that the addition of sodium hypochlorite in both dilutions significantly alters all of the properties examined. On the contrary, the addition of glutaraldehyde or chlorhexidine in the structure of the dental stone had no significant changes.

The results communicated so far in the literature are quite controversial. The purpose of the present study is to analyze how two commonly disinfectants / antiseptics incorporated in different percentages in dental stone, affect the linear dimensional stability, flexural and compressive strength of the dental models.

## Materials and Methods

The present study was conducted in an environment with temperature of 25°C ( $\pm$  2°C) and relative humidity of 50% ( $\pm$  10%), according to the American Dental Association Specification (A.D.A.) No. 25.

The materials used were type IV super hard cast dental stone INFRAROCK (INFRADENT), sodium hypochlorite 1%, chlorhexidine gluconate 2%. The instruments used were caliper, an expansion-measuring device (SAM EMI 100), and an universal testing machine.

The study was conducted on 5 groups as follows:

- GROUP 1: control (dental stone is prepared according to manufacturer's instructions);
- GROUP 2: replacement of 100% of the water with sodium hypochlorite 1%;
- GROUP 3: replacement of 50% of the water with sodium hypochlorite 1%;
- GROUP 4: replacement of 100% of the water with chlorhexidine gluconate 2%;
- GROUP 5: replacement of 50% of the water with chlorhexidine gluconate 2%;

The dental stone was prepared with vacuum mixer and then placed in the container of expansion-measuring device under vibration; this device will measure the expansion setting and dimensional change ( $\Delta L$ ) up to two hours.

The sample, after setting, was removed from the container and measured using a caliper, to determine the length (L); the length on initial setting was then calculated:  $L_0 = L - \Delta L$ . The percentage of dimensional change was calculated:  $ADL = \Delta L / L_0 \times 100$ .

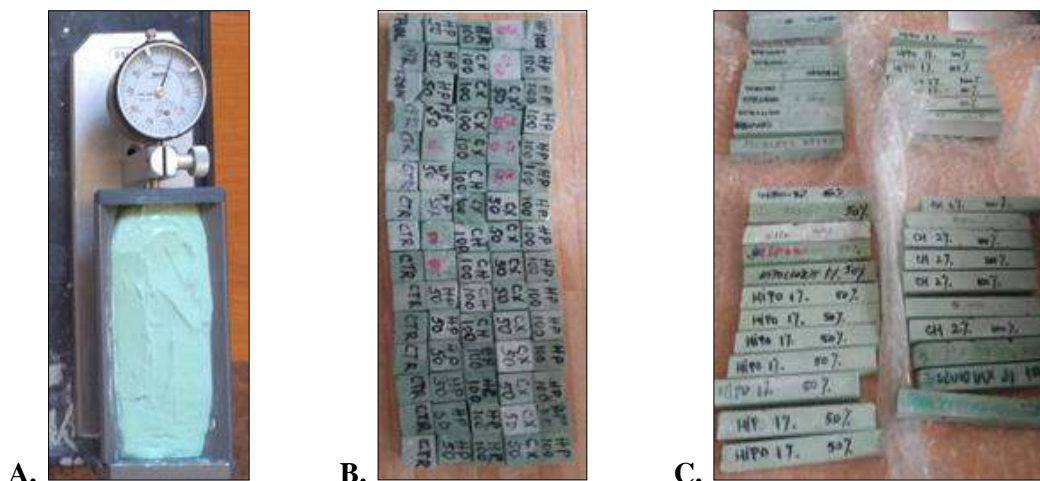

**Figure 1.** Samples prepared for testing:

**A.** Setting linear changes; **B.** Resistance to bending forces; **C.** Resistance to compression forces.

After the dimensional measurements, the samples were prepared for the strength tests by converting into a rectangular form 10 cm long and 4 mm<sup>2</sup> per section. 5 samples presenting casting defects were removed. Among samples considered valid, a number of 15 or cut

to standard sizes, each sample into five equal parts, resulting cubes with 2 cm side – samples for compression tests. Samples were then loaded on the universal-testing machine and the results were recorded as graphics by computer.



Figure 2. Samples loaded for compression and bending test.

## Results

### The results of dimensional changes

Results recorded after the measurement of parameters  $L_0$ ,  $L$  and  $ADL$  were summarized in a table and statistically analyzed.

For the parameter  $L_0$  the ANOVA test has been

applied ( $F(4.49) = 3.9, p = 0.008$ ) with planned contrasts to see if the averages of four groups (2, 3, 4 and 5) were different than the standard group (1). The average Group 2 was significantly higher than the standard group,  $t(45) = 2.85, p = 0.007$ . For the group 3 ( $p = 0.508$ ), the group 4 ( $p = 0.404$ ) and group 5 ( $p = 0.975$ ) averages were not significantly different from the standard group.

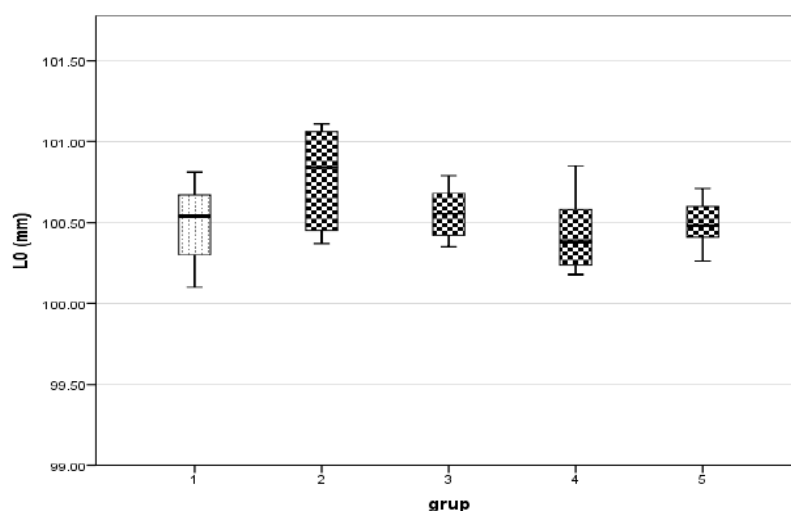

Graphic 1. Comparative analysis of samples size at the initial setting,  $L_0$ .

For the parameter  $L$ , the ANOVA test has been applied ( $F(4.49) = 3.5, p = 0.014$ ) with planned contrasts to see if the averages of four groups (2, 3, 4 and 5) were different from the standard group (1).

The average Group 2 was significantly higher than the standard group,  $t(45) = 2.51, p = 0.016$ . For Group 3 ( $p = 0.787$ ), Group 4 ( $p = 0.312$ ) and group 5 ( $p = 0.803$ ), the averages were not significantly different from the standard group.

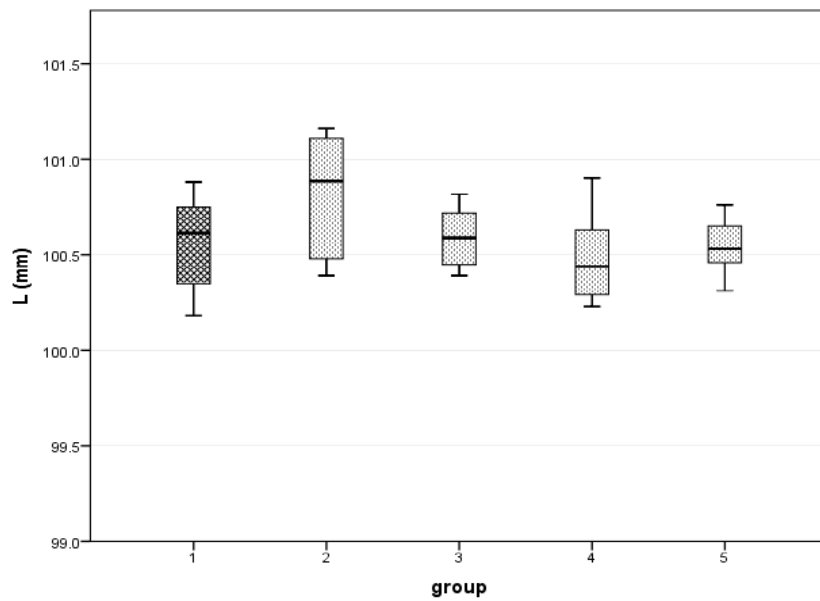

**Graphic 2.** Comparative analysis of samples size at final setting L.

For the parameter  $\Delta L$ , the ANOVA test has been applied ( $F(4,49) = 34.1, p < 0.001$ ) with planned contrasts to see if the averages of four groups (2, 3, 4 and 5) are different than the standard group (1). We found that all

groups average were significantly lower than the standard group, as follows: Group 2  $t(17.9) = -6.76, p < 0.001$ ; group 3  $t(13.5) = -10.44, p < 0.001$ ; Group 4,  $t(14.3) = -5.52, p < 0.001$ ; group 5,  $t(8.12) = -6.03, p < 0.001$ .

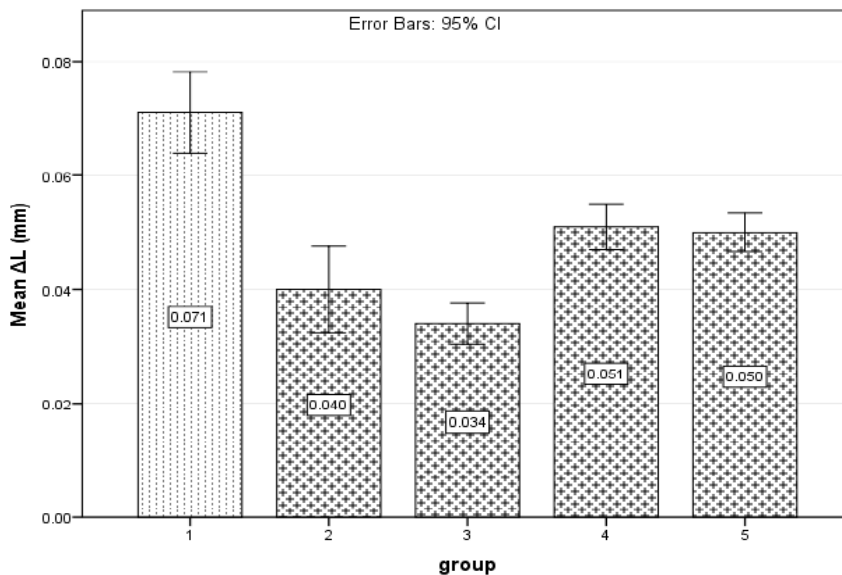

**Graphic 3.** Comparative analysis of dimensional change of samples  $\Delta L$ .

For the ADL parameter, we have applied ANOVA test ( $F(4,49) = 34.1, p < 0.001$ ) with planned contrasts to see if the averages of four groups (2, 3, 4 and 5) were different than the standard group (1). We found that all the groups had the average significantly lower than the

standard group, as follows: Group 2,  $t(17.9) = -6.76, p < 0.001$ ; Group 3,  $t(13.5) = -10.44, p < 0.001$ ; Group 4,  $t(14.3) = -5.52, p < 0.001$ ; group 5,  $t(12.8) = -6.03, p < 0.001$ .



When recording original setting length ( $L_0$ ), statistical analysis revealed a significantly higher difference compared to the test control group in groups where all the water had been replaced by sodium hypochlorite/disinfectant, which intensified setting expansion. The remaining combinations showed no changes. Dimensional change after addition of sodium hypochlorite was expected, but because this substance is known to be an inhibitor of the setting reaction, the result is different from that obtained in our previous study (A.D.A., SFARGHIU & al [14, 15]), reports being done this time to the average of the control group tests.

After two hours of the initial setting ( $L$ ), changes of chlorhexidine and 50% sodium hypochlorite 1% groups are insignificant compared to the control group.

Statistically analyzing the average of setting expansion values ( $\Delta L$ ) versus standard group, a decrease in all variants in which antiseptic were used has been observed, as well as in calculating percentage dimensional changes in control group. The results are similar to data from Renz and Martin' studies (RENTZIA & al, MARTIN & al [16, 17]), pointing out that chemical agents which adjust the setting time generally reduce the mass expansion of dental stone obtained from the hydration of calcium sulphate.

### Compression test results

Using a universal loading machine Zwick Roell with 10 kN nominal load, rectangular samples were tested to compression. Samples have a section of the  $a \cdot a$  and height  $h$ . The values were  $a = 15 \text{ mm}$  and  $h = 20 \text{ mm}$ . Opposite sides, where load was applied were perfectly flat and parallel only to some of the specimens. Thus, in most cases, failure (breaking) was produced progressively, starting from the most prominent areas. Therefore, shortened force curves have been obtained (Fig. 3) in a zigzag shape and breaking forces had lower values than specimens without deficiencies. In Figure 4 all curves recorded are shown on the same graph.

For each series of tests, were detained ten results for samples where failure forces had had highest values. Breaking tensions and the compressive modulus of elasticity were determined by the following equations:

$$\sigma_{rup} = \frac{F_{rup}}{a^2} \quad E = \frac{\Delta F}{a^2} \cdot \frac{h}{\Delta h}$$

Variations of and are considered on a linear area of shortening-force curve.

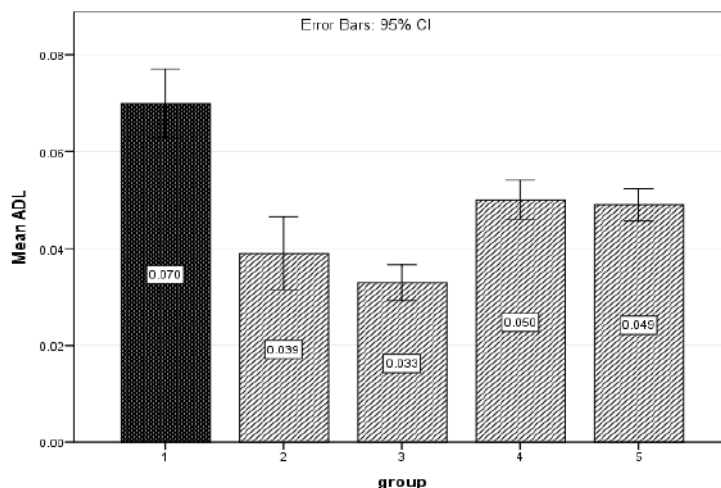

Graphic 4. Variation of the dimensional change of ADL.

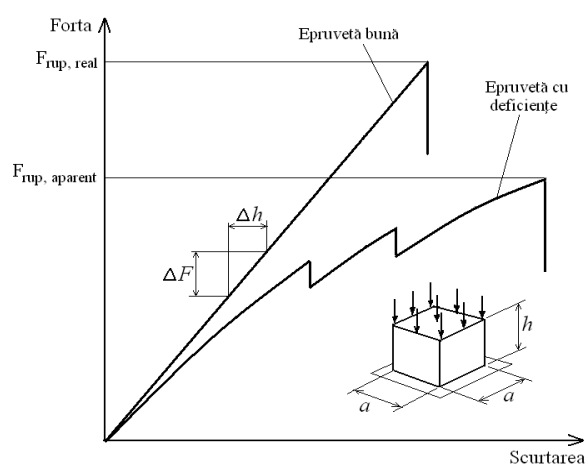

Figure 3. Force curve shortened in zigzag shape.

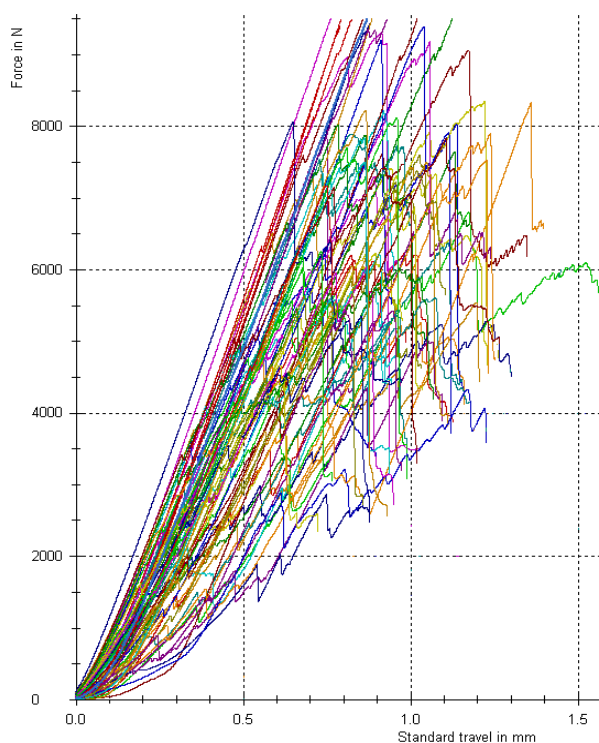

Figure 4. Curves recorded in the test compression.

Tabel VII. CTR (grup control)

Proba	$F_{rup}$ [N]	$\sigma_{rup}$ [MPa]
CTR 1	9200	40,9
CTR 2	7900	35,1
CTR 3	9190	40,8
CTR 4	8220	36,5
CTR 5	9860	43,8
CTR 6	9500	42,2
CTR 7	9680	43,0
CTR 8	7740	34,4
CTR 9	7230	32,1
CTR 10	9920	44,1

$$\sigma_{rup,med} = 39,2 \text{ MPa } E_{med} = 1050 \text{ Mpa}$$

Tabel VIII. HI 50 (grup 3)

Proba	$F_{rup}$ [N]	$\sigma_{rup}$ [MPa]
HI 50 1	9400	41,7
HI 50 2	7530	33,4
HI 50 3	9860	43,8
HI 50 4	7830	34,8
HI 50 5	8020	35,6
HI 50 6	8070	35,8
HI 50 7	9790	43,5
HI 50 8	7900	35,1
HI 50 9	9910	44,0
HI 50 10	8120	36,1

$$\sigma_{rup,med} = 38,3 \text{ MPa } E_{med} = 1110 \text{ MPa}$$

Tabel IX. HI 100 (grup 2)

Proba	$F_{rup}$ [N]	$\sigma_{rup}$ [MPa]
HI 100 1	6370	28,3
HI 100 2	7500	33,3
HI 100 3	7430	33,0
HI 100 4	6220	27,6
HI 100 5	8220	36,5
HI 100 6	6190	27,5
HI 100 7	6040	26,8
HI 100 8	7180	31,9
HI 100 9	6260	27,8
HI 100 10	9510	42,2

$$\sigma_{rup,med} = 31,5 \text{ Mpa } E_{med} = 1040 \text{ MPa}$$

Tabel X. CX 50 (grup 5)

Proba	$F_{rup}$ [N]	$\sigma_{rup}$ [MPa]
CX 50 1	6230	27,6
CX 50 2	6810	30,2
CX 50 3	5760	25,6
CX 50 4	9310	41,3
CX 50 5	5750	25,5
CX 50 6	7410	32,9
CX 50 7	9620	42,7
CX 50 8	7870	34,9
CX 50 9	5740	25,5
CX 50 10	7980	35,4

$$\sigma_{rup,med} = 32,1 \text{ MPa } E_{med} = 1100 \text{ MP}$$

Tabel XI. CX 100 (grup 4)

Proba	$F_{rup}$ [N]	$\sigma_{rup}$ [MPa]
CX 100 1	8040	35,7
CX 100 2	8330	37,0
CX 100 3	7300	32,4
CX 100 4	8350	37,1
CX 100 5	9060	40,2
CX 100 6	7650	34,0
CX 100 7	9430	41,9
CX 100 8	7260	32,2
CX 100 9	7600	33,7
CX 100 10	9400	41,7

$$\sigma_{rup,med} = 36,6 \text{ MPa } E_{med} = 1180 \text{ MPa}$$

Figure 5. The results recorded on study groups in compression test.

In conclusion,  $\sigma_{rup,med} = 2 < 5 < 4 < 3 < 1$ ,  $E_{med} = 2 < 1 < 5 < 3 < 4$ .

Compressive breaking tension values in all cases were lower than in the control group, the brittle samples are those with the addition of 100% sodium hypochlorite 1%, followed by the group with 50% chlorhexidine gluconate 2%, 100% gluconate 2% chlorhexidine, 50% water with 1% sodium hypochlorite; compression modulus of elasticity decreased when 100% addition of hypochlorite, while in other cases, increased compared to the control group. The study results contradict previous studies mentioned (ZARAKANI & al, SWATANTRA & al, BREault & al. [9, 10, 11]), showing that the addition of disinfectants have influence on quality of dental stone for models.

### Flexural test results

Flexural strength of samples was tested in an universal loading machine from Lloyd Instruments LRX plus with nominal load of 5 kN. Samples were processed to rectangular section of  $a \times a$  and a length of 100 mm. Requirements were  $a = 15$  mm, but processing was grossly and deviations were detected quite high of the odds. Therefore, actual values for each sample have been considered.

In Figure no 6 the charging scheme commonly called "three-point bending" is shown.

The distance between the support rollers was  $l = 80$  mm.

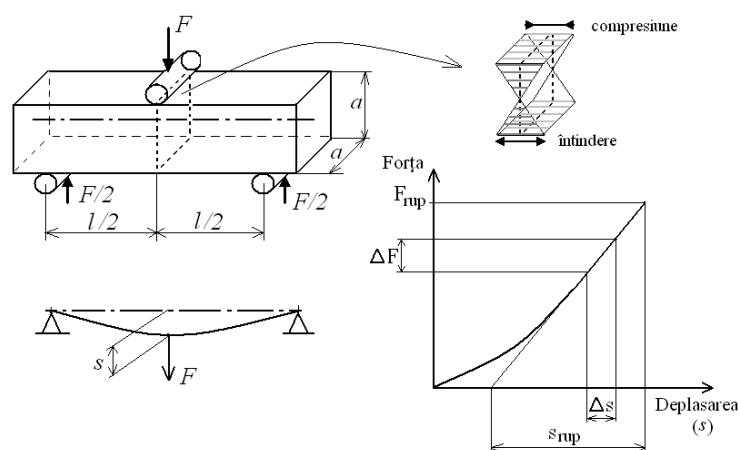

Figure 6. Loading scheme

Breaking tension and compression modulus of elasticity were determined with the known relationship from the resistance of materials:

$$\sigma_{rup} = \frac{F_{rup} \cdot l}{4 \cdot W}, \quad E = \frac{\Delta F \cdot l^3}{48 \cdot I \cdot \Delta s},$$

In which  $I = \frac{a^4}{12}$ ,  $W = \frac{a^3}{6}$ , and variations  $\Delta F$  and

of  $\Delta h$  are considered on a linear area of displacement-force curve.

The middle section of the sample is the most strained, therefore deformations occur and longitudinal tensions have extremes values, with stretching on the lower surface and compression on the top surface.

Tabel XII. CTR (grup control)

Proba	Sectiune	$I$ [mm <sup>4</sup> ]	$W$ [mm <sup>3</sup> ]	$F_{rup}$ [N]	$\Delta F$ [N]	$\Delta s$ [mm]	$\sigma_{rup}$ [MPa]	$E$ [MPa]
CTR 1	15,5 x 15,5	4810	620,6	470	225	0,2	15,1	2494
CTR 2	15,5 x 15,5	4810	620,6	471	271	0,22	15,1	2731
CTR 3	15 x 15	4218	562,5	400	165	0,15	14,2	2781
CTR 4	15 x 15	4218	562,5	390	190	0,16	13,9	3003
CTR 5	16 x 16	5461	682,6	531	231	0,16	15,5	2820
CTR 6	15,5 x 15,5	4810	620,6	436	236	0,2	14,0	2616
CTR 7	15 x 15	4218	562,5	375	175	0,16	13,3	2766

$$\sigma_{rup,med} = 14,4 \text{ MPa} \quad E_{med} = 2744 \text{ MPa}$$

Tabel XIII. HI 1% 50% (grup 3)

Proba	Sectiune	$I$ [mm <sup>4</sup> ]	$W$ [mm <sup>3</sup> ]	$F_{rup}$ [N]	$\Delta F$ [N]	$\Delta s$ [mm]	$\sigma_{rup}$ [MPa]	$E$ [MPa]
HI 50 1	15 x 15	4218	562,5	379	178	0,146	13,4	3082
HI 50 2	16 x 16	5461	682,6	445	202	0,147	13,0	2684
HI 50 3	16 x 16	5461	682,6	463	233	0,187	13,5	2433
HI 50 4	15,5 x 15,5	4810	620,6	439	239	0,188	14,1	2819
HI 50 5	15,5 x 15,5	4810	620,6	452	252	0,218	14,5	2563
HI 50 6	15 x 15	4218	562,5	366	165	0,129	13,0	3234
HI 50 7	15 x 15	4218	562,5	343	143	0,134	12,2	2698
HI 50 8	16,5 x 16,5	6176	748,7	538	238	0,186	14,3	2210
HI 50 9	16 x 16	5461	682,6	443	143	0,122	13,0	2289
HI 50 10	16,5 x 16,5	6176	748,7	471	190	0,161	12,6	2038

$$\sigma_{rup,med} = 13,3 \text{ MPa} \quad E_{med} = 2605 \text{ MPa}$$

Tabel XIV. HI 1% 100% (grup 2)

Proba	Sectiune	$I$ [mm <sup>4</sup> ]	$W$ [mm <sup>3</sup> ]	$F_{rup}$ [N]	$\Delta F$ [N]	$\Delta s$ [mm]	$\sigma_{rup}$ [MPa]	$E$ [MPa]
HI 100 1	15 x 15	4218	562,5	363	44	0,042	12,9	2649
HI 100 2	16 x 16	5461	682,6	479	249	0,207	14,0	2349
HI 100 3	16 x 16	5461	682,6	475	279	0,242	13,9	2251
HI 100 4	15,5 x 15,5	4810	620,6	433	233	0,178	13,9	2902
HI 100 5	15 x 15	4218	562,5	327	126	0,109	11,6	2923
HI 100 6	15 x 15	4218	562,5	335	134	0,125	11,9	2710
HI 100 7	15,5 x 15,5	4810	620,6	457	219	0,185	14,7	2625

$$\sigma_{rup,med} = 13,2 \text{ MPa} \quad E_{med} = 2630 \text{ MPa}$$

Tabel XV. CX 2% 50% (grup 5)

Proba	Sectiune	$I$ [mm <sup>4</sup> ]	$W$ [mm <sup>3</sup> ]	$F_{rup}$ [N]	$\Delta F$ [N]	$\Delta s$ [mm]	$\sigma_{rup}$ [MPa]	$E$ [MPa]
CX 50 1	15,5 x 15,5	4810	620,6	375	201	0,17	12,1	2622
CX 50 2	15 x 15	4218	562,5	365	171	0,14	13,0	3088
CX 50 3	15,5 x 15,5	4810	620,6	386	186	0,152	12,4	2713
CX 50 4	15,5 x 15,5	4810	620,6	396	196	0,189	12,7	2300
CX 50 5	16 x 16	5461	682,6	404	204	0,156	11,8	2554
CX 50 6	16 x 16	5461	682,6	408	208	0,172	11,9	2362
CX 50 7	15,5 x 15,5	4810	620,6	384	183	0,137	12,4	2962

Figure 7. Test results of bending strength on the studied groups.

In conclusion,  $\sigma_{rup,med} = 5 < 2 < 3 = 4 < 1$ ;  $E_{med} = 3 < 2 < 5 < 1 < 4$ .

Breaking bending (flexural) tension decreases in all situations where antiseptic was added. The breaking modulus of elasticity compared to the control increased by the addition of 100% chlorhexidine gluconate 2%, while in all other circumstances there has been a decrease.

## Conclusions

Within the limits of the method used in the current study, we can say that the addition of disinfectants in the dental stone caused the following changes:

- When recording initial setting length ( $L_0$ ), as well as after two hours after initial setting ( $L$ ), statistical analysis revealed a significantly higher difference compared to the control group of tests, where all of the water had been replaced by sodium hypochlorite substance that has intensified setting expansion. The remaining combinations showed no changes;
- Statistically analyzing the average of setting expansion values ( $\Delta L$ ) versus standard group, there is a decrease in all situations in which disinfectants were used, similar situation highlighted when calculating percentage dimensional change;
- Compressive breaking tension in all cases was lower than in the control group, the brittle samples are those with the addition of 100% sodium hypochlorite 1%, followed by the group with 50% chlorhexidine gluconate 2%, 100% gluconate 2% chlorhexidine, 50% water with 1% sodium hypochlorite; compression modulus of elasticity decreased when 100% addition of hypochlorite, while in the other cases, increased compared to the control group.
- Breaking flexural tension decreased in all situations where antiseptic has been added. The breaking modulus of elasticity compared to the control increased by the addition of 100% chlorhexidine gluconate 2%, while in all other circumstances there has been a decrease.

## Acknowledgement

In this article, all the authors have equal contributions to the first author.

## References

1. M.A. ABDULLAH. Surface detail, compressive strength and dimensional accuracy of gypsum casts after repeated immersion in hypochlorite solution. *J. Prosthet. Dent.* June, 95(6), 462-468 (2006).
2. R.N. KUMAR, R.N. REDDY, S. KARTHIGEYAN, R. MANIKANDAN, The effect of repeated immersion of gypsum cast in sodium hypochlorite and glutaraldehyde on its physical properties. *J Pharm Bioallied Science.* August, (Suppl 2), S353-S357 (2012).
3. P.K. PAL, S. KAMBLE, R.R. CHAURASIA, et al. Evaluation of different disinfectants on dimensional accuracy and surface quality of type IV gypsum casts retrieved from elastomeric impression materials. *J Int Oral Health.* March, 6(3), 77-81 (2014).
4. S.M. MANSFIELD, J.M. WHITE. Antimicrobial effects from incorporation of disinfectants into gypsum casts. *Int J Prosthodont.* 4,180-185 (1991).
5. M.A. STERN, G.H. JOHNSON, L.B. TOOLSON. An evaluation of dental stones after repeated exposure to spray disinfectants: Part I. Abrasion and compressive strength. *J Prosthet Dent.* 5, 713-718 (1991).
6. T. DONOVAN, W. CHEE. Preliminary investigation of a disinfected gypsum die stone. *Int J Prost.* 2, 245-248 (1989).
7. K.W. SCHUTT. Bactericidal effect of disinfectant dental stone on irreversible hydrocolloid impressions and stone casts. *J Prosthet Dent.* 62, 605-607 (1989).
8. O.C. TEBROK, R.L. ENGELMEIER, T.G. MAYFIELD, et al. Managing dental impressions and casts of patients with communicable diseases. *Gen Dent.* 37, 490-495 (1989).
9. H. ZARAKANI, N. KARIMI, S. SADRIYA, A. FAYAZ. Comparison of setting time, setting expansion and compressive strength of gypsum casts produced by mixing of gypsum powder with distilled water or 0.05% sodium hypochlorite. *J Dent Sch.* 31(2), 89-96 (2013).
10. A. SWATANTRA, G. KAVITA. An evaluation of properties of die stone after adding antimicrobial agents. *J. of Pierre Fauchard Academy (India Section).* December, 22(4), 131-139 (2008).
11. L.G. BREAUULT, J.R. PAUL, S.O. HONDRUM, L.C. CHRISTENSEN. Die stone disinfection: Incorporation of sodium hypochlorite. *J Prosthodont.* March, 7(1), 13-16 (1998).
12. K.M. ABDELAZIZ, E.C. COMBE, J.S. HODGES. The effect of disinfectants on the properties of dental gypsum: mechanical properties. *J Prosthodont.* September, 11(3), 161-167 (2002).
13. M.G. LUCAS, J.N. ARIOLI-FILHO, S.S. NOGUEIRA, et al. Effect of incorporation of disinfectant solutions on setting time, linear dimensional stability and detail reproduction in dental stone casts. *J Prosthodont.* August, 18(6), 521-526 (2009).
14. AMERICAN DENTAL ASSOCIATION: Specification No. 25 for dental gypsum products. In *ADA: Guide to dental materials and devices.* Chicago, ADA, 1972/1973, pp. 253-258.
15. L.G. SFARGHIU, L. OANCEA, R. LIȚESCU, et al. The Influence of disinfectants incorporation on die stone linear expansion. *Rom Biotechnol Lett.* 21 (3), 11585-11590 (2016).
16. A. RENTZIA., D.C COLEMAN., M.J. O'DONNELL, et al. Disinfection procedures: Their efficacy and effect on dimensional accuracy and surface quality of an irreversible hydrocolloid impression. *J of Dent.* 39, 133 – 140 (2011).
17. N. MARTIN, M.V MARTIN., N.M. JEDYNA-KIEWICZ. The dimensional stability of dental impression materials following immersion in disinfecting solutions. *Dent Mat.* 23, 760-768 (2007).